

# Mountain Birdwatch 2.0

## Volunteer Manual 2016



Bicknell's Thrush

© Jeff Nadler

# Mountain Birdwatch 2.0

## Volunteer Training Manual

### Table of Contents

Background and Objectives .....	2
Protocol Development .....	7
Navigating to the Survey Stations.....	8
Bird Survey Methods and Cone Count Protocol .....	8
Data Entry and Data Submission .....	12
Literature Cited .....	14
Finding Your Way with Map and Compass .....	17
7 Principles of Leave No Trace .....	21
Mountain Birdwatch Equipment List.....	23
<u>Identification Guide to the Northeast's Montane Forest Songbirds</u> .....	24
Sample Datasheet.....	26
Field Datasheet.....	27

### Background and Objectives

This protocol represents an effort to strengthen monitoring of high-elevation landbirds from the Catskill Mountains of New York to the Cape Breton Highlands of Nova Scotia through improved coordination, statistical design, and data management. It builds on knowledge and experience gained by several institutions over sixteen years of mountain bird research and monitoring in the region. A standardized international protocol, aligned with the information needs of land stewards and policy-makers, will promote conservation of a vulnerable bird community. A unified approach will also achieve efficiencies necessary to sustain high-elevation landbird monitoring over the long term.

The survey design and standard operating procedures presented here reflect the guiding principles of *Opportunities for Improving Avian Monitoring*, a report of the Monitoring Subcommittee of the North American Bird Conservation Initiative (U.S. NABCI 2007). Our collaboration formed in 2006 under the aegis of the Northeast Coordinated Bird Monitoring Partnership ([www.nebirdmonitor.org](http://www.nebirdmonitor.org)) and operates in concert with the International Bicknell's Thrush Conservation Group ([www.bicknellsthrush.org](http://www.bicknellsthrush.org)), the Appalachian Trail MEGA-Transect, and the Monitoring and Performance Reporting Framework for the Northeast Association of Fish and Wildlife Agencies. Participating agencies and organizations will begin implementing this protocol during the 2009 breeding season. Interest from the Appalachian Mountain Joint Venture, the National Park Service, and the Appalachian Trail Conservancy may lead to adaptation of this program to high-elevation bird communities of the mid-Atlantic and southern Appalachian regions.

## Rationale for Monitoring High-elevation Birds

High-elevation forests of New York, northern New England, and southeastern Canada comprise a small fraction of the landscape, however they make a large contribution to the region's avian diversity. Stands of balsam fir (*Abies balsamea*) and red spruce (*Picea rubra*), which thrive in the cool climate of upper elevations, harbor a number of bird species that are uncommon or absent at lower altitudes, including Bicknell's Thrush (*Catharus bicknelli*). Bicknell's Thrush is a globally rare species and the region's only endemic songbird. It breeds in montane fir-spruce thickets from the Catskill Mountains of New York northeast to the Katahdin region of Maine (Atwood et al. 1996) and north to the Laurentian Mountains of southern Quebec (Gauthier and Aubry 1996). It also occurs in highland conifers of northern New Brunswick and Cape Breton, Nova Scotia, in addition to coastal conifers of Cape Breton and the Gulf of St. Lawrence in Quebec (Ouellet 1993, Nixon 1999) (Fig. 1). Use of mixed forest is seldom observed in the United States, but surveys in Quebec (Y. Aubry pers. comm.), New Brunswick (Nixon et al. 2001) and Nova Scotia (Campbell and Whittam 2006) indicate some use of regenerating timberlands with a variable hardwood component. The winter range of Bicknell's Thrush is restricted to the Greater Antilles, with the majority of birds concentrated in montane broadleaf forests of the Dominican Republic (Rimmer et al. 2001). This habitat has been reduced to approximately 10% of its historic extent in recent decades (Stattersfield et al. 1998).

**Figure 1.** Known breeding range of Bicknell's Thrush.

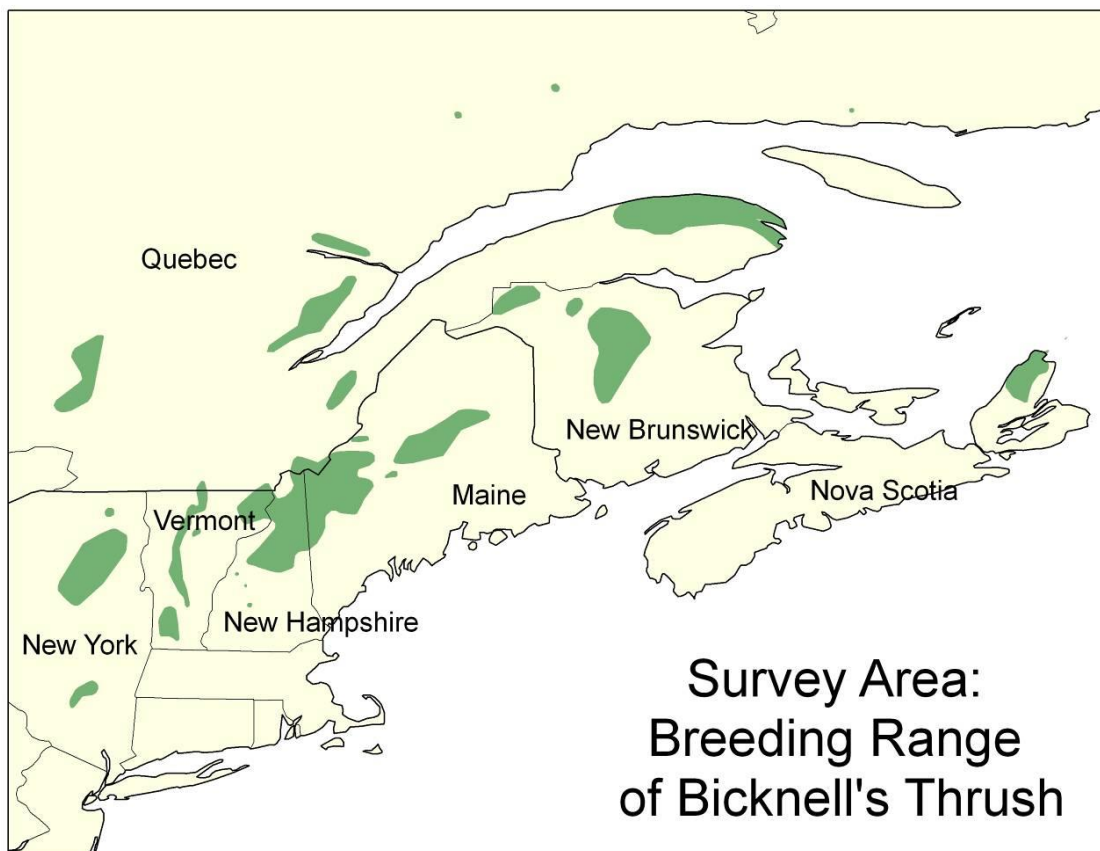

Because of its scarcity, selective habitat use, and limited breeding and wintering ranges, Bicknell's Thrush has received Special Concern designation from New York, Vermont, New Hampshire and Maine, as well as from the Committee on the Status of Endangered Wildlife in Canada (COSEWIC 1999). Partners in Flight included the thrush on the North American Watch List for Landbirds, calling for immediate action to maintain or increase its numbers in the Northern Forest Biome (Rich et al. 2004). In response to this call, the International Bicknell's Thrush Conservation Group will release a conservation action plan in the spring of 2009. The plan will identify opportunities to restore winter habitat in the Dominican Republic, enhance breeding habitat in areas now managed for timber, and address other potentially limiting factors through research, education, and policy improvements. The plan's overall conservation goal will be to increase the global Bicknell's Thrush population by 25% in 50 years, with most of the gains expected to be made during the final 30 years of this period. Achieving the goal requires a monitoring program to measure population status, illuminate limiting factors, and assess effects of management and policy decisions. A multi-species survey could produce information needed to conserve other high-elevation songbirds, some of which are also considered vulnerable.

Mountain ecosystems provide a unique opportunity for measuring effects of anthropogenic activity, as they are among the most sensitive indicators of environmental change. They are more susceptible than lower areas to the effects of global warming, atmospheric pollution, and certain land uses, such as wind power and ski area development. Even a slight increase in growing-season temperature could allow hardwoods to encroach on high-elevation fir and spruce (Beckage et al. 2008) and dramatically reduce critical bird habitat (Rodenhouse et al. 2008). High doses of acid compounds from atmospheric deposition may leach calcium from thin and poorly buffered soils and limit populations through egg-shell defects (Hames et al. 2002, Graveland and vanderWal 1996). Bioaccumulation of toxic methylmercury in mountain food webs has the potential to reduce the survival of avian insectivores (Rimmer et al. 2005).

Unfortunately, the significance of these threats is not well known. And while previous efforts to monitor high-elevation landbirds have provided a solid foundation for this protocol, they are not sufficient to meet the need for a regionally coordinated and statistically robust approach to the challenge of mountain bird conservation.

#### A Brief History of High-elevation Bird Monitoring in the Region

Prior to 1991, there was no organized attempt to survey high-elevation breeding birds in the northeastern U.S. or adjacent regions of Canada, except for individual research projects and breeding bird atlases. A small number of Breeding Bird Survey routes intersected Bicknell's Thrush habitat in Quebec, New Hampshire, Maine, and Nova Scotia; however, these produced just 48 encounters with the species between 1966 and 2006 (USGS Patuxent Wildlife Research Center 2006). Since 1991, several programs have emerged to fill the gap (Table 1).

Findings published to date justify the current level of concern. Between 1993 and 2003, the core population of Bicknell's Thrush, which breeds in the White Mountain National Forest, numbered as few as 4,900 individuals (Hale 2006) and experienced annual declines of 7% per year along 40 survey routes (King et al. 2008). Yellow-bellied Flycatcher and Magnolia Warbler also declined sharply over the same period, while no species registered significant gains. Six years of

data from New Brunswick and Nova Scotia (2002-2007) showed an abrupt drop in Bicknell's Thrush numbers in Atlantic Canada (Campbell et al. 2007, Whittam and Campbell unpubl. data), while annual surveys at Mont Gosford, Quebec, from 2001-2007 showed a clear decline in the number of stations occupied by Bicknell's (Aubry unpubl. data). In addition, climate change projections derived from survey data indicate that suitable Bicknell's Thrush habitat may be lost from the United States following increases in summer temperatures that are projected to occur this century (Rodenhouse et al. 2008).

Although these studies have demonstrated the vulnerability of Bicknell's Thrush, they are limited by several important shortcomings. Among these are differences in survey timing and protocol, which hamper integration of results. Also, there is redundant monitoring effort in New Hampshire's White Mountains and inadequate coverage in Quebec and northwestern Maine.

**Table 1.** High-elevation landbird surveys performed in the northeastern United States and eastern Canada since 1991.

<b>Program</b>	<b>Lead Institution(s)</b>	<b>State / Province</b>	<b>Timeframe</b>
Green Mountain National Forest high-elevation bird monitoring	Green Mountain National Forest, University of Vermont	VT	1991-2000
Vermont Forest Bird Monitoring Program high-elevation surveys	Vermont Institute of Natural Science	VT, ME	1991- 2000
Bicknell's Thrush distribution survey	Vermont Institute of Natural Science and Manomet Center for Conservation Sciences	MA, NY, VT, NH, ME	1992-1994
Bicknell's Thrush distribution survey	Canadian Wildlife Service	QC	1998-present
White Mountain National Forest high-elevation bird monitoring	White Mountain National Forest and Audubon Society of New Hampshire	NH	1993-present
Mountain Birdwatch (Version 1.0)	Vermont Institute of Natural Science / Vermont Center for Ecostudies, U.S. Fish and Wildlife Service	NY, VT, NH, ME	2000-present
High-Elevation Landbird Program	Bird Studies Canada	NB, NS	2002-present

A new, coordinated approach, incorporating enhanced statistical design, can optimize power to detect trends. Greater attention to environmental covariates can reveal factors underlying population change. And implementation from New York to Nova Scotia can generate population and habitat models at the scale necessary to guide conservation of Bicknell's Thrush and other vulnerable species. Additional advantages of coordination include cost-effective training, data management, and reporting.

## Geographic Scope and Target Species

Mountain Birdwatch is focused on breeding songbirds within the current breeding range of Bicknell's Thrush (Fig. 1). A few dozen bird species regularly breed at upper elevations in the focal region. From this group, we selected ten species for targeted monitoring based on level of conservation concern, degree of habitat specialization and range restriction, ease of identification, and expected detectability in the field (Table 2).

In addition, we will monitor the abundance of red squirrels (*Tamiasciurus hudsonicus*), whose predation on open-cup nests in the focal habitat causes widespread reproductive failure following biennial pulses of cone mast by balsam fir (McFarland unpubl. data).

**Table 2.** Target species.

Common Name	Scientific Name
Yellow-bellied Flycatcher	<i>Empidonax flaviventris</i>
Black-capped Chickadee	<i>Poecile atricapilla</i>
Boreal Chickadee	<i>Poecile hudsonica</i>
Winter Wren	<i>Troglodytes troglodytes</i>
Bicknell's Thrush	<i>Catharus bicknelli</i>
Swainson's Thrush	<i>Catharus ustulatus</i>
Hermit Thrush	<i>Catharus guttatus</i>
Blackpoll Warbler	<i>Dendroica striata</i>
Fox Sparrow	<i>Passerella iliaca</i>
White-throated Sparrow	<i>Zonotrichia albicollis</i>
Red Squirrel	<i>Tamiasciurus hudsonicus</i>

## Monitoring Goals

1. To measure the annual population status of target species in terms of distribution, abundance/density, and occupancy
2. To measure changes in the population status of target species over time
3. To relate population status and trend information to biotic and abiotic variables that may affect the target species

## Programmatic Goals

1. To make observational data (date, location, count, etc.) and associated metadata publicly available for visualization and download through the Avian Knowledge Network (AKN), while recognizing legal, institutional, proprietary, and other constraints.
2. To provide decision-makers with tools and analyses to conserve high-elevation birds in the Northern Appalachian and Laurentian Regions, such as:
  - a. models of abundance and occupancy for each target species
  - b. a wind farm siting assessment

- c. density estimates for target species
  - d. a range-wide Bicknell's Thrush population viability analysis
  - e. a model that projects the effects of climate change on target species
3. To increase public understanding of the ecology, status, and conservation requirements of high-elevation songbirds in the Northern Appalachian and Laurentian Regions (using public presentations, citizen science, online applications, newsletters, and personal outreach).

## **Protocol Development**

The Mountain Birdwatch Protocol Development Team considered the advantages and disadvantages of a variety of survey techniques, including simple counts, repeated simple counts, distance sampling, double observer, double sampling, time-of-removal, time-of-detection, and repeated "presence-absence" (actually, detection-nondetection) surveys in an occupancy framework. Our deliberations were informed by results of previous high-elevation bird surveys (Lambert 2005, Campbell et al. 2007, King et al. 2008) and investigations of Bicknell's Thrush habitat selection (Campbell and Whittam 2006, Connolly et al. 2002, Frey 2008, Hale 2006), home range characteristics (Collins 2007 and Rimmer et al. 2001), vocalization rates (Rimmer et al. 1996, Ball 2000), and detectability (Frey 2008, DeLuca unpubl. data, Aubry unpubl. data). The emerging literature on sources of observer error and bias also proved useful in the development of this protocol (Alldredge et al. 2007a, b, c; Rosenstock et al. 2002; Simons et al. 2007).

Our intent was to develop methods that: ensure a variety of options for analysis, incorporate an understanding of the ecology and behavior of the target species, and correspond with the capacity of observers to collect reliable information. Mountain Birdwatch protocols aim to balance a theoretically ideal approach within practical constraints in order to ensure the continuity and quality of survey results.

### Summary of Pilot Season: June 2008

Two protocol options were piloted by volunteer observers, hired technicians, and staff in June 2008. One protocol consisted of monitoring all target species using repeated simple counts with a concurrent, time-of-detection protocol for monitoring Bicknell's Thrush (protocol A). The second protocol consisted of "presence-absence" surveys for all target species concurrent with a time-of-detection protocol for Bicknell's Thrush (protocol B). Both protocols used three distance bands for Bicknell's Thrush (0-25 m, 25-50 m, and > 50 m) and two distance bands for all other species (< 50 m and > 50 m). The tradeoffs associated with each protocol were analyzed based on the survey results and feedback from observers. Brian Mitchell, Jason Riddle, and Frank Rivera analyzed the results using occupancy, time-of-detection, and distance estimation methods. Covariates included in analysis were observer type, protocol type, wind, time of day, date, distance, and elevation above a latitude-dependent threshold (Lambert et al. 2005).

Observers in the U.S. also submitted an evaluation form with their survey results. They used a scale of 1 to 5 to indicate their level of agreement with several positive statements regarding the protocol. Responses were generally favorable from testers of both pilot protocols. In fact, testers

of both protocols were equally likely to remain a Mountain Birdwatch volunteer despite a distinct difference in protocol complexity.

A thorough evaluation of the statistical analyses, observer feedback, and programmatic goals was undertaken to come to final agreement on a regionally coordinated protocol. The final protocol consists of a time-of-detection protocol for Bicknell's Thrush (each individual is tracked on a minute-by-minute basis during the first ten minutes of the survey), concurrent with four 5-min repeated counts for all target species. This is the same as the 2008 pilot protocol A with the addition of a fourth distance band for Bicknell's Thrush detections in the first 10 minutes (50-100 m).

## **Navigating to the Survey Stations**

Each survey route contains three to six survey stations along a section of trail or road. Some sites are permanently marked with fire tacks (small, reflective tacks placed in a tree; these tacks are for location confirmation once you have navigated to your point). Volunteers will be provided with a topographic map of their route depicting the location of each survey station along the road or trail. Each map is accompanied by station documentation, including latitude/longitude coordinates, a photo, and a written description. The distance between each point is 250 m as the crow flies. This amounts to approximately 325 steps for a person of average height walking on flat or gently rolling terrain. If the station has changed since it was documented, such as a trail reroute or blow down, please record the changes and return to the coordinator with your data. If appropriate photos of your stations are not provided and if you have a digital camera with you, please take pictures at each station and note the direction each picture faces.

**Note:** To see additional pictures of your route, please visit <http://www.flickr.com/search/> and search the People category for "Mountain Birdwatch". Click on "Mountain Birdwatch 2.0" and go to "Sets". Additional pictures of most routes are available here- navigate through the sets to find your route's number/name.

## **Bird Survey Methods and Cone Count Protocol**

The Mountain Birdwatch protocol consists of four consecutive 5-min counts at each survey station, for a total sampling period of 20 min per point. Observers are asked to conduct repeated simple counts for all target species during each 5-min period. During the first 10 minutes of the survey, observers will track individual Bicknell's Thrushes within four distance categories on a minute-by-minute basis. Up to six points will be surveyed along a trail or road on a single visit in June. A count of visible fir and spruce cones is conducted immediately after the bird survey at each station.

### Timing of the Survey

Surveys should be conducted during the month of June. While surveys can be conducted until the last day of June, we ask volunteers to plan to conduct their survey between 1 June and 21 June in the United States. If you find that you are unable to conduct your survey, **please notify the MBW director as soon as possible and no later than 21 June.**



In order to increase the likelihood of detecting Bicknell's Thrush, which is most vocal during the pre-dawn period, observers should begin the survey 45 min before sunrise. This will also ensure that the survey is finished by 8:00 am when vocal activity may be waning. Observers should determine local sunrise using a published resource, such as the U.S. Naval Observatory ([http://aa.usno.navy.mil/data/docs/RS\\_OneYear.php](http://aa.usno.navy.mil/data/docs/RS_OneYear.php)) or The Weather Network (<http://www.theweathernetwork.com/>).

### Survey Conditions

Inclement weather can greatly reduce an observer's ability to detect birds in the field (Simons et al. 2007). Each survey should be conducted in temperatures above 35°F and when precipitation and wind conditions permit. Occasional drizzle or a brief shower is acceptable, but steady drizzle or prolonged rain is not. A light wind with occasional gusts is acceptable, but a steady breeze that causes small trees to sway (>20 mph) is not. If cold temperatures, rain, and/or high winds are encountered, delay the survey until 30 minutes after the conditions have improved. If poor conditions persist, the survey should be rescheduled for another morning.

### Pre-survey Set-up

Once positioned at the first survey location, pace out 25 m in one direction along the trail and place a marker. The marker will be used to help judge the distance to birds detected during the survey. Return to the survey point and wait for about 30 seconds to catch your breath and allow time for the birds to settle back into the area. Location and weather conditions can be noted at this time. When you are ready, start a digital stopwatch or suitable time-keeping device. Don't forget to remove your marker when you have finished the survey!

### Repeated simple counts

At each survey location, conduct four consecutive 5-min counts over a total sampling period of 20 minutes. Within each 5-min interval, record all individuals in the target species group (see sample datasheet p. 23). To reduce the risk of counting the same individual twice, use the datasheet to map each individual and its observed or presumed movements. Mark each individual bird/squirrel on the circle in its approximate location within or outside of the 50-m radius circle. Note whether each bird/squirrel was initially heard or visually identified by writing an "h" or "v" next to the species code. If the bird/squirrel moves to another location within the 5-minute period, draw a line to the new location and note whether it was heard ("h") or visually ("v") identified at the new location.

### Bicknell's Thrush Protocol

Collect additional information on Bicknell's Thrush (BITH) during the first 10 min of the 20-min sampling period. Use the circular plots for the first and second count periods on the datasheet to map each BITH by writing "BITH" in the approximate location of **each** individual (see sample datasheet p. 23). Pay special attention to the four distance categories (0-25 m, 25-50 m, 50-100 m, and beyond 100 m) marked on the sheet. The circles are meant to help you keep track of each

individual bird's movements and to estimate density and abundance, so please use your best judgment to place the bird in the appropriate distance band.

Below each "BITH" notation, record the minute in which it was detected and the form of detection. Record the minute of detection as the number of minutes that have elapsed since you started the count (the minute shown on your stop watch, from 0-9), followed by an "h" if the bird was initially heard or a "v" if it was initially visually detected. If you hear and see a bird, note this with "hv", although you will only enter your *initial* detection type into the database. Separate multiple detections of an individual by commas such that a possible record might read (1h, 3h, 4hv), indicating that the thrush was heard in the second and fourth minutes and heard and seen in the fifth minute. After the first 10 minutes of the survey, continue to record Bicknell's Thrush according to the repeated simple count protocol for the other target species.

Please see the enclosed document, "Additional Notes on Navigating to your Site and Conducting your Survey" for additional information and responses to frequently asked questions.

### Cone Count Protocol

After completing each bird count, collect an index of cone mast at each station. This information will be used in conjunction with red squirrel and avian abundance data to assess the relationship between pulses in cone mast and population dynamics of high-elevation birds and their principal nest predator. The procedure, based on LaMontagne et al. (2005), involves three steps.

1. At each survey station, find the nearest balsam fir tree in each cardinal direction (N, E, S, W) with branches that are visible for 3 m down from the top. If no tree fits this description, move along the trail for up to 50 m and stop upon locating suitable trees. If no suitable tree is found, note this on the datasheet with an 'X' to distinguish from a count of zero cones. The fir should be at least 4 m tall to ensure that it is of flowering age, unless it is near treeline or in stunted conditions, in which case the closest tree that is at least 2/3 of the canopy height should be chosen. **IMPORTANT:** Do not select the closest tree with cones. Select the closest tree that is of flowering age (as described above), which may or may not have cones.
2. If your tree has fewer than ~100 cones and it is easy to see each distinct cone, count the number of **fresh** cones in the top 3 m of the tree using binoculars. Do not move from your vantage point while counting cones (only cones visible from your position will be counted). If your tree has more than ~100 cones, it may be difficult to count each individual cone. Focus on one group of cones within the top 3 m of the tree and count the fresh cones within that area. Then, look at the entire top 3 m of the tree and estimate the number of similar groups of cones. Multiply the number of cones in your group by the number of cone groups to estimate the total number of fresh cones on the tree. Do not move from your vantage point while counting cones (only cones visible from your position will be counted). Record the number of cones on the datasheet in the appropriate cells.
3. Repeat steps 1 and 2 for red spruce in the U.S. and black and white spruce in Canada. To qualify for the count, red spruce trees should be canopy height or higher, while black and white spruce trees should be at least 2/3 of the canopy height. If you are near treeline,

pick a tree that is at least 2/3 canopy height. If no tree fits this description, move along the trail (in either direction) for up to 50 m and stop upon locating a suitable tree. If no suitable tree is found, note this on the datasheet with an 'X' to distinguish from a count of zero cones.

### Identification of Tree Species

Balsam fir (*Abies balsamea*):

Balsam fir is the dominant species in the high-elevation spruce-fir forest. It can be easily identified by the medium-sized cones pointing up from the branches. In June, the cones will be small and green (Figure 1). Be careful to differentiate between the fresh growth on the end of the branches and the new cones (this should be easy using binoculars).

Balsam fir bark is smooth with resin blisters. The needles are typically flat and positioned on the branches in a flat plane, though variation in this trait may occur in subalpine environments.

Red spruce (*Picea rubens*):

Red spruce trees are less common and have small cones hanging down from the branches. Spruce trees hold onto their old cones and appear brown (Figure 2). New cones will be green and the scales will be closed (Figure 3). Red spruce bark is scaly. The needles are round and occur all around the branches.

Figure 1. Young Balsam fir cones are light green in June.



Figure 2. Red spruce trees have a “prickly” appearance and last year’s small red cones are often visible.

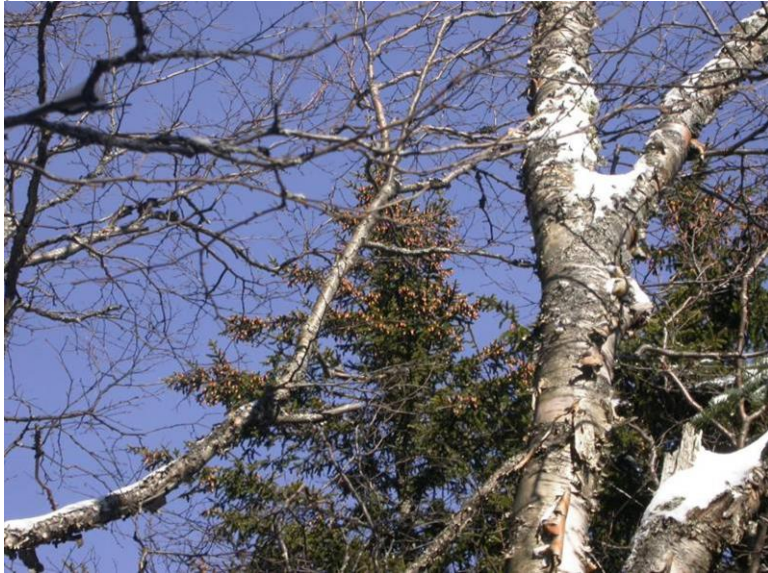

Figure 3. Close-up of young spruce cones.



## Data Entry and Data Submission

Congratulations! You have survived the black flies, arrived at your mountain route before the sun, located your survey stations, and maybe even heard a Bicknell’s Thrush or two (or at least a White-throated Sparrow)! There are just a few more steps to complete your Mountain Birdwatch volunteer commitment.

**Notify the MBW director that your survey is complete:** As soon as you complete your survey, please email Judith Scarl ([jscarl@vtecostudies.org](mailto:jscarl@vtecostudies.org)) to notify her that you were able to survey your route.

**Tally your data:** Transfer your survey data from the bulls-eye diagram to the tally boxes at the bottom of each sheet. Make sure to double-check to ensure you have accurately tallied the number of individuals of each species at each distance class.

**Submit your data online:** Mountain Birdwatch requires both online submission of data and hard copy data sheets. The online data entry site is accessed at:

**<http://www.vtecostudies.org/MBW/dataentry.html>.**

Create an Account- If you did not create an account a previous year, please create a data submission account. At the initial screen, click “Create an Account” and fill out the required information. Once you create an account, it may take up to 48 hours for your account to be activated; check your email spam folder if you do not receive a confirmation. Please contact Judith Scarl if your account is not activated within this period.

Log in to your Account: At the sign-in screen, enter your username and password to log in. **Note:** If you created an account in 2011 or 2012 but cannot access your

account in 2013, please do NOT create a second account- contact Judith Scarl to resolve this issue.

Create new form: Upon logging in, you will be directed to a screen that lists all of the data forms you have submitted in the past. If this is your first time with MBW, this screen will not list any data forms. To create a new form to enter this year's data, select "Submit Observations" under the Forms menu at the top left of the page. A blank form will appear.

Submit observations: Submit one online form for each point. Enter data as it appears on your hard copy data sheets. In the "station" section, a drop-down menu for "route" will appear once you select the state/province in which you surveyed a route. Several routes have similar names to another route (for example, Bolton Mountain, Bolton Southeast, and Bolton Southwest)- please ensure you select the correct route. Enter all bird count data in the Bird Count Grid. Note that you must enter Bicknell's Thrush data for the first 10 minutes of the count in the bottom grid.

Bicknell's Thrush instructions: Bicknell's Thrush data for the first 10 minutes of each count is submitted in the bottom grid. Each BITH row represents an individual bird (BITH-1 is the first BITH detected, BITH-2 the second, and so on). Columns are divided into minutes. For each time interval in which you detected a BITH, enter the **distance class** at which you observed that BITH under H (if you heard the bird) or S (if you saw it).

Repeat for each additional point surveyed: Each point will have its own online form. When you have entered all of your survey points, your "home" screen should list each point with the correct route name and survey date.

**Mail hard copy data sheets:** Please photocopy your data sheets for your records and mail the hard copy data sheets to Judith Scarl at Vermont Center for Ecostudies, PO Box 420, Norwich, VT 05055.

**Please submit ALL data NO LATER THAN 15 July 2015 so that we can begin analysis!**

## Literature Cited

- Allredge, M. W, T. R. Simons, and K. H. Pollock. 2007a. A field evaluation of distance measurement error in auditory avian point count surveys.
- Allredge, M. W, T. R. Simons, and K. H. Pollock. 2007b. Factors affecting aural detections of songbirds. *Ecological Applications* 17(3):948–955.
- Allredge, M. W, T. R. Simons, K. H. Pollock, and K. Pacifici. 2007c. A field evaluation of the time-of-detection method to estimate population size and density for aural avian point counts. *Avian Conservation and Ecology – Écologie et conservation des oiseaux* 2(20):13. [online] URL: <http://www.ace-eco.org/vol2/iss2/art13/>
- Atwood, J. A., C. C. Rimmer, K. P. McFarland, S. H. Tsai, and L. N. Nagy. 1996. Distribution of Bicknell's Thrush in New England and New York. *Wilson Bulletin* 108:650–661.
- Ball, M. 2000. Vocal behaviour of Bicknell's Thrush (*Catharus bicknelli*). Master's thesis. Dalhousie University, Halifax, Nova Scotia.
- Beckage, B., B. Osborne, D. G. Gavin, C. Pucko, T. Siccama, and T. Perkins. 2008. A rapid upward shift of a forest ecotone during 40 years of warming in the Green Mountains of Vermont. *Proceedings of the National Academy of Sciences* 105:4197–4202.
- Campbell, G., and B. Whittam. 2006. Bicknell's Thrush habitat in Nova Scotia's industrial forest: final report to the Nova Forest Alliance and Stora Enso Port Hawkesbury, Ltd. Unpublished Report. Bird Studies Canada (Atlantic Region), Sackville, New Brunswick. 17 pp.
- Campbell, G., B. Whittam, and G. Robertson. 2007. High Elevation Landbird Program 5-year report. Unpublished Report. Bird Studies Canada (Atlantic Region), Sackville, New Brunswick. 16 pp.
- Collins, B. B. 2007. Spatial Analysis of Home Range, Movement Patterns, and Behavioral Ecology of Bicknell's Thrush, *Catharus bicknelli*, in Vermont. Master's thesis. Antioch University, Keene, New Hampshire.
- Connolly, V., G. Seutin, J.-P. L. Savard, and G. Rompré. 2002. Habitat use by Bicknell's Thrush in the Estrie Region, Québec. *Wilson Bulletin* 114:333–341.
- COSEWIC 1999. COSEWIC assessment and status report on the Bicknell's thrush *Catharus bicknelli* in Canada. Committee on the Status of Endangered Wildlife in Canada. Ottawa. v + 43 pp.
- Frey, S. J. K. 2008. Metapopulation dynamics and multi-scale habitat selection of a montane forest songbird. Master's thesis. University of Vermont, Burlington, Vermont.
- Gauthier, J., and Y. Aubry. 1996. The Breeding Birds of Quebec: Atlas of the Breeding Birds of Southern Quebec. Province of Quebec Society for the Protection of Birds and Canadian Wildlife Service, Montreal.
- Graveland, J., and R. vanderWal. 1996. Decline in snail abundance due to soil acidification causes eggshell defects in forest passerines. *Oecologia* 105:351–360.

- Hale, S. R. 2006. Using satellite imagery to model distribution and abundance of Bicknell's Thrush (*Catharus bicknelli*) in New Hampshire's White Mountains. *Auk* 123:1038–1051.
- Hames, R. S., K. V. Rosenberg, J. D. Lowe, S. E. Barker, and A. A. Dhondt. 2002. Adverse effects of acid rain on the distribution of the Wood Thrush (*Hylocichla mustelina*) in North America. *Proceedings of the National Academy of Sciences of the United States of America* 99:11235–11240.
- King, D. I., J. D. Lambert, J. P. Buonaccorsi, and L. S. Prout. 2008. Avian population trends in the vulnerable montane forests of the northern Appalachians, USA. *Biodiversity Conservation* 17:2691–2700.
- Lambert, J. D., K. P. McFarland, C. C. Rimmer, S. D. Faccio, and J. L. Atwood. 2005. A practical model of Bicknell's Thrush distribution in the northeastern United States. *Wilson Bulletin* 117:1–11.
- Lambert, J. D. 2005. Mountain Birdwatch 2004: Final report to the U.S. Fish and Wildlife Service. VINS Technical Report 05-1. Vermont Institute of Natural Science, Woodstock, Vermont. 15 pp.
- Nixon E. 1999. COSEWIC status report on the Bicknell's thrush *Catharus bicknelli* in Canada, in COSEWIC assessment and status report on the Bicknell's thrush *Catharus bicknelli* in Canada. Committee on the Status of Endangered Wildlife in Canada. Ottawa. 1–43 pp.
- Nixon, E. A., S. B. Holmes & A. W. Diamond. 2001. Bicknell's Thrushes (*Catharus bicknelli*) in New Brunswick clear cuts: their habitat associations and co-occurrence with Swainson's Thrushes (*Catharus ustulatus*). *Wilson Bulletin* 113:33–40.
- Ouellet, H. 1993. Bicknell's Thrush: taxonomic status and distribution. *Wilson Bulletin* 105:545–572.
- Rich, T. D., C. J. Beardmore, H. Berlanga, P. J. Blancher, M.S. W. Bradstreet, G. S. Butcher, D. W. Demarest, E. H. Dunn, W. C. Hunter, E. E. Inigo-Elias, J. A. Kennedy, A. M. Martell, A. O. Panjabi, D. N. Pashley, K. V. Rosenberg, C. M. Rustay, J. S. Wendt, T. C. Will. 2004. Partners in Flight North American Landbird Conservation Plan. Cornell Lab of Ornithology, Ithaca, New York. 84 pp.
- Rimmer, C. C., J. L. Atwood, K. P. McFarland, and L. R. Nagy. 1996. Population density, vocal behavior, and recommended survey methods for Bicknell's Thrush. *Wilson Bulletin* 108(4):639–649.
- Rimmer, C. C., K. P. McFarland, W. G. Ellison, and J. E. Goetz. 2001. Bicknell's Thrush (*Catharus bicknelli*). No. 592, In A. Poole and F. Gill (Eds.). *The Birds of North America*. Academy of Natural Sciences, Philadelphia, Pennsylvania, and American Ornithologists' Union, Washington, D.C. 28 pp.
- Rimmer, C. C., K. P. McFarland, D. C. Evers, E. K. Miller, Y. Aubry, D. Busby, and R. J. Taylor. 2005. Mercury levels in Bicknell's Thrush and other insectivorous passerines in montane forests of northeastern North America. *Ecotoxicology* 14:223–240.
- Rodenhouse, N.L., S.N. Matthews, K.P. McFarland, J.D. Lambert, L.R. Iverson, A. Prasad, T.S. Sillett, and R.T. Holmes. 2008. Potential effects of climate change on birds of the Northeast. *Mitigation and Adaptation Strategies for Global Change* 13:517–540.

- Rosenstock, S. S., D. R. Anderson, K. M. Giesen, T. Leukering, and M. F. Carter. 2002. Landbird counting techniques: current practices and an alternative. *Auk* 119:46–53.
- Simons, T. R., M. W. Alldredge, K. H. Pollock, and J. M. Wettröth. 2007. Experimental analysis of the auditory detection process on avian point counts. *Auk* 124(3):986–999.
- Stattersfield, A. J., M. J. Crosby, A. D. Long, and D. C. Wege. 1998. Endemic bird areas of the world: priorities for biodiversity conservation. BirdLife International, BirdLife Conservation Serial no. 7.
- U.S. Geological Survey Patuxent Wildlife Research Center. 2006. North American Breeding Bird Survey current data 1966–2005. Available: <http://www.pwrc.usgs.gov/bbs/retrieval> [2006, February 1].
- U.S. North American Bird Conservation Initiative Monitoring Subcommittee. 2007. Opportunities for Improving Avian Monitoring. U.S. North American Bird Conservation Initiative Report. 50 pp. Available from the Division of Migratory Bird Management, U.S. Fish and Wildlife Service, Arlington, Virginia; on-line at <http://www.nabci-us.org/>.



## Finding Your Way with Map and Compass



Finding Your Way with Map and Compass  
Fact Sheet 079-99 (February 2000)

[| From Near to Far: Distance](#) | [| From Here to There: Determining Direction](#) |  
[| A Word of Caution](#) | [| Information](#) |

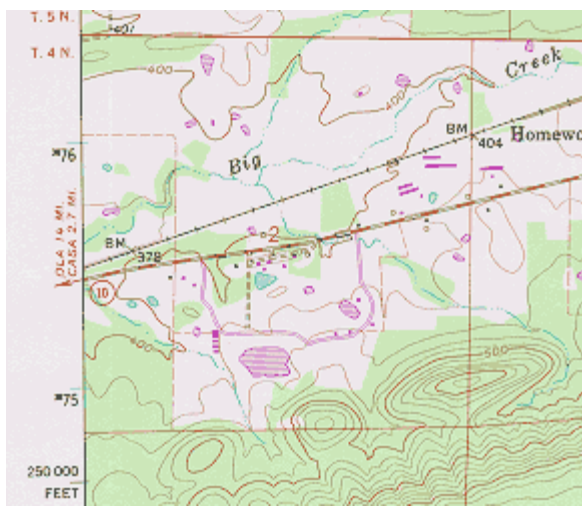

Part of a 7.5-minute topographic map at 1:24,000 scale

A topographic map tells you where things are and how to get to them, whether you're hiking, biking, hunting, fishing, or just interested in the world around you. These maps describe the shape of the land. They define and locate natural and manmade features like woodlands, waterways, important buildings, and bridges. They show the distance between any two places, and they also show the direction from one point to another.

Distances and directions take a bit of figuring, but the topography and features of the land are easy to determine. The topography is shown by contours. These are imaginary lines that follow the ground surface at a constant elevation; they are usually printed in brown, in two thicknesses. The heavier

lines are called index contours, and they are usually marked with numbers that give the height in feet or meters. The contour interval, a set difference in elevation between the brown lines, varies from map to map; its value is given in the margin of each map. Contour lines that are close together represent steep slopes.

Natural and manmade features are represented by colored areas and by a set of standard symbols on all U.S. Geological Survey (USGS) topographic maps. Woodlands, for instance, are shown in a green tint; waterways, in blue. Buildings may be shown on the map as black squares or outlines. Recent changes in an area may be shown by a purple overprint. a road may be printed in red or black solid or dashed lines, depending on its size and surface. A list of [symbols](#) is available from the [Earth Science Information Center \(ESIC\)](#).

### From Near to Far: Distance

Maps are made to scale; that is, there is a direct relationship, a ratio, between a unit of measurement on the map and the actual distance that same unit of measurement represents on the ground. If, for instance, 1 inch on the map represents 1 mile (which converts to 63,360 inches)

on the ground, the map's scale is 1:63,360. Below is a listing of the scales at which some of the more popular USGS maps are compiled.

Map Name Series	Scale	1 inch represents	1 centimeter represents	Map area (approximate square miles)
Puerto Rico 7.5 minute	1:20,000	1,667 feet	200 meters	71
7.5-minute	1:24,000	2,000 feet	240 meters	40 to 70
7.5- by 15-minute	1:25,000	2,083 feet	250 meters (about)	98 to 140
Alaska	1:63,360	1 mile	634 meters (about)	207 to 281
Intermediate	1:50,000	0.8 mile	500 meters (about)	County
Intermediate	1:100,000	1.6 mile	1 kilometer (about)	1,568 to 2,240
United States	1:250,000	4 miles	2.5 kilometers (about)	4,580 to 8,669

A convenient way of representing map distance is by the use of a graphic scale bar. Most USGS topographic maps have scale bars in the map margin that represents distances on the map in miles, feet, and kilometers. The table below shows the corresponding area of coverage for each scale and the linear distance that each scale represents in inches and centimeters.

### From Here to There: Determining Direction

To determine the direction, or bearing, from one point to another, you need a compass as well as a map. Most compasses are marked with the four cardinal points —north, east, south, and west— but some are marked additionally with the number of degrees in a circle (360 north is 0 or 360, east is 90, south is 180, and west is 270). Both kinds are easy to use with a little practice. The illustrations on the reverse side show how to read direction on the map.

One thing to remember is that a compass does not really point to true north, except by coincidence in some areas. The compass needle is attracted by magnetic force, which varies in different parts of the world and is constantly changing. When you read north on a compass, you're really reading the direction of the magnetic north pole. A diagram in the map margin will show the difference (declination) at the center of the map between compass north (magnetic north indicated by the MN symbol) and true north (polar north indicated by the "star" symbol). This diagram also provides the declination between true north and the orientation of the Universal Transverse Mercator (UTM) grid north (indicated by the GN symbol). The declination diagram is only representational, and true values of the angles of declination should be taken from the numbers provided rather than from the directional lines. Because the magnetic declination is computed at the time the map is made, and because the position of magnetic north is constantly changing, the declination factor provided on any given map may not be current. Contact the National Geophysical Data Center (NGDC) to obtain current and historical magnetic declination information for any place in the United States.

NGDC General Information: 303-497-6826

E-mail: [info@ngdc.noaa.gov](mailto:info@ngdc.noaa.gov)

Web site: <http://www.ngdc.noaa.gov/> or <http://www.ngdc.noaa.gov/seg/potfld/geomag.shtml>

Taking a compass bearing from a map:

1. Draw a straight line on the map passing through your location and your destination and extending across any one of the map borders.
2. Center the compass where your drawn line intersects the map border, align the compass axis N-S or E-W with the border line, and read on the compass circle the true bearing of your drawn line. Be careful to get the bearing in the correct sense because a straight line will have two values 180° apart. Remember north is 0, east is 90, and so on.
3. To use this bearing, you must compensate for magnetic declination. If the MN arrow on the map magnetic declination diagram is to the right of the true north line, subtract the MN value. If the arrow is to the left of the line, add the value.



(1) Drawing a straight line over the map edge



(2) Reading the compass on the map

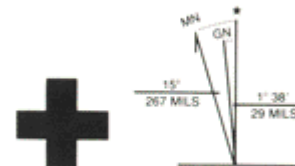
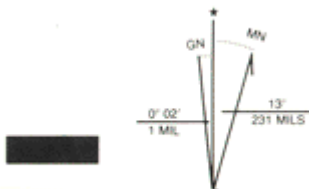

(3) Using the magnetic declination diagrams

## **A Word of Caution**

Compass readings are also affected by the presence of iron and steel objects. Be sure to look out for—and stay away from—pocket knives, belt buckles, railroad tracks, trucks, electrical lines, GPS unit, and so forth when using a compass in the field.

## **Information**

For information on these and other USGS products and services, call 1-888-ASK-USGS, use the Ask.USGS fax service, which is available 24 hours a day at 703-648-4888, or visit the general interest publications Web site on mapping, geography, and related topics at <http://mapping.usgs.gov/mac/isb/pubs/pubslists/index.html>.

Please visit the USGS home page at <http://www.usgs.gov/>.

*Any use of trade, product, or firm names is for descriptive purposes only and does not imply endorsement by the U.S. Government.*

*This document has undergone official review and approval for publications established by the National Mapping Division, U.S. Geological Survey.*

*Some figures have been modified or added to improve the scientific visualization of information.*

[U.S. Department of the Interior](#)

[U.S. Geological Survey](#)

509 National Center, Reston, VA 20192, USA

**URL:** <http://mapping.usgs.gov/mac/isb/pubs/factsheets/fs07999.html>

**Page Maintainer:** USGS Mapping Applications Center

**Contact:** [macweb@usgs.gov](mailto:macweb@usgs.gov)

**Last modified:** 15:31:11 Wed 08 Mar 2000

[USGS Privacy Statement](#)

## 7 Principles of Leave No Trace

### 1. Plan Ahead and Prepare

- Know the regulations and special concerns for the area you'll visit.
- Prepare for extreme weather, hazards, and emergencies.
- Schedule your trip to avoid times of high use.
- Visit in small groups when possible. Consider splitting larger groups into smaller groups.
- Repackage food to minimize waste.
- Use a map and compass to eliminate the use of marking paint, rock cairns or flagging.

### 2. Travel and Camp on Durable Surfaces

- Durable surfaces include established trails and campsites, rock, gravel, dry grasses or snow.
- Protect riparian areas by camping at least 200 feet from lakes and streams.
- Good campsites are found, not made. Altering a site is not necessary.
  - In popular areas:**
    - Concentrate use on existing trails and campsites.
    - Walk single file in the middle of the trail, even when wet or muddy.
    - Keep campsites small. Focus activity in areas where vegetation is absent.
  - In pristine areas:**
    - Disperse use to prevent the creation of campsites and trails.
    - Avoid places where impacts are just beginning.

### 3. Dispose of Waste Properly

- Pack it in, pack it out. Inspect your campsite and rest areas for trash or spilled foods. Pack out all trash, leftover food, and litter.
- Deposit solid human waste in catholes dug 6 to 8 inches deep at least 200 feet from water, camp, and trails. Cover and disguise the cathole when finished.
- Pack out toilet paper and hygiene products.
- To wash yourself or your dishes, carry water 200 feet away from streams or lakes and use small amounts of biodegradable soap. Scatter strained dishwater.

### 4. Leave What You Find

- Preserve the past: examine, but do not touch, cultural or historic structures and artifacts.
- Leave rocks, plants and other natural objects as you find them.
- Avoid introducing or transporting non-native species.
- Do not build structures, furniture, or dig trenches.

### 5. Minimize Campfire Impacts

- Campfires can cause lasting impacts to the backcountry. Use a lightweight stove for cooking and enjoy a candle lantern for light.
- Where fires are permitted, use established fire rings, fire pans, or mound fires.
- Keep fires small. Only use sticks from the ground that can be broken by hand.
- Burn all wood and coals to ash, put out campfires completely, then scatter cool ashes.

## 6. Respect Wildlife

- Observe wildlife from a distance. Do not follow or approach them.
- Never feed animals. Feeding wildlife damages their health, alters natural behaviors, and exposes them to predators and other dangers.
- Protect wildlife and your food by storing rations and trash securely.
  - **Note: Bear resistant canisters are required in the Eastern High Peaks of the Adirondacks. Elsewhere, it is strongly recommended that you store food and other odor-emitting supplies in a safe location outside of your sleeping area.**
- Control pets at all times, or leave them at home.
- Avoid wildlife during sensitive times: mating, nesting, raising young, or winter.

## 7. Be Considerate of Other Visitors

- Respect other visitors and protect the quality of their experience.
- Be courteous. Yield to other users on the trail.
- Step to the downhill side of the trail when encountering pack stock.
- Take breaks and camp away from trails and other visitors.
- Let nature's sounds prevail. Avoid loud voices and noises

## Mountain Birdwatch Equipment List

The following materials are required to prepare for and conduct your mountaintop survey. Refer to this list when packing for the field.

### Materials Provided by VCE

- Mountain Birdwatch manual
- CD recording of songbirds
- survey route maps
- point location form
- data sheets

### You Provide

- stopwatch
- compass
- thermometer
- clip board
- pencils
- binoculars
- field guide
- GPS (strongly recommended)

### For a Day Hike

- food and water
- sturdy boots, gaiters optional
- wind jacket/rain gear
- warm layer (wool or synthetic fleece)
- hat
- flashlight with extra batteries
- first-aid kit
- waterproof matches
- insect repellent and/or bug net
- sunscreen
- toilet paper and trowel
- whistle
- pocket knife

### For an Overnight—all of the above, plus

- permission to camp, where required
- backpacking stove and fuel
- cooking kit and eating utensils
- sleeping bag in waterproof sac
- sleeping pad
- tent
- extra clothes and socks

## Identification Guide to the Northeast's Montane Forest Songbirds

Species	Visual identification <sup>1</sup>	Vocalizations <sup>2</sup>
Yellow-bellied Flycatcher	Small flycatcher. Triangular head. White eye ring. Lower mandible orange. Brownish-olive upperparts. Breast has olive wash. Yellowish throat, belly and undertail coverts. Wing bars-white in adults, buffy in immatures. Fall birds have yellower underparts than Spring birds.	song a liquid <i>che-lek</i> , also a rising <i>per-wee</i> ; call a long emphatic, rising, <i>chewee</i>
Boreal Chickadee	Short bill. Gray-brown crown and back. Face white near bill but mostly gray. Black throat. Gray wings and tail. Brown flanks, white belly. Sexes similar.	No known song; call a nasal <i>tseek-a-day-day</i>
Black-capped Chickadee	Short bill. Black crown and throat. White face. Pale gray upperparts. White edges to wing coverts. Grayish-white underparts. Rusty flanks. Sexes similar Often found in small flocks.	<i>chick-a-dee-dee-dee</i> song is a clear, whistled <i>fee-bee</i> or <i>fee-bee-ee</i>
Winter Wren	Short, thin bill. Indistinct supercilium. Reddish-brown upperparts (more reddish in eastern United States birds). Buffy breast with dark barring on belly and undertail coverts. Wings and tail barred with black. Very short tail frequently held upright. Pink legs. Sexes similar. Frequently found very near the ground in brush piles, root tangles and along stream banks.	song is a rapid series of melodious trills, call an explosive <i>chimp-chimp</i>
Bicknell's Thrush	Olive-brown upperparts. Tail usually a chestnut brown. Gray, indistinct eye ring. Gray cheeks. Dark spots on breast. Underparts white with grayish flanks. Pink legs. Thin bill with pale base to lower mandible. Sexes similar. Often forages on forest floor.	song a soft, opening <i>chook-chook</i> followed by descending <i>wee-o</i> , <i>wee-o</i> , <i>wee-o-ti-t-ter-ee</i> (somewhat like a Veery's); call an emphatic <i>peer</i>
Swainson's Thrush	Olive-brown upperparts. Buffy spectacles. Dark spots on breast. Underparts white with brownish flanks. Pink legs. Thin bill with pale base to lower mandible. Sexes similar. Often forages on forest floor.	song an ascending spiral of varied whistles; call an abrupt <i>whit</i>
Hermit Thrush	Brownish gray back. Reddish tail. Conspicuous white eye ring. Dark spots on breast. Underparts white with brownish to grayish flanks. Pink legs. Thin bill with pale base to lower mandible. Sexes similar. Often forages on forest floor.	song a serene series of clear flutelike notes with similar phrases repeated at different pitches; call a low <i>chuck</i>
Blackpoll Warbler	Small, active, insect-eating bird. White wing bars. Thin, pointed bill. White spots visible on underside of tail. Yellow legs. Male has black crown and malar streak, upperparts streaked black and white, underparts mostly white with black streaks on flanks. Female plumage similar, but lacks distinctive head pattern. Greenish crown, nape and back with thin black streaks. Indistinct supercilium. Breast paler than upperparts with faint darker streaks. White belly and undertail coverts.	song a series of high <i>tseet</i> notes that crescendos in the middle



White-throated Sparrow	Large sparrow. Dark conical bill. Long slightly forked tail. Pink legs. Bold black and white (or tan) head stripes. Yellow lores. White throat contrasting with gray breast and cheeks. Brown back with dark streaks. Brown wings with two white wingbars. Whitish belly.	song a thin whistle, <i>oh sweet Canada Canada Canada</i> ; calls include a loud <i>pink</i> and a sharp <i>tseep</i>
Fox Sparrow	Large sparrow. Conical bill with yellow lower mandible. Thick malar streak. Heavy spotting below. Eastern “Red” race: Gray crown, nape and back. Bright rusty rump and tail. Rusty brown cheeks, malar streak, streaks on back, wings and spotting below.	loud, sweet, melodic song, a series of clear musical notes and sliding whistles; call a <i>tschup</i> note
Red Squirrel	Small rufous-colored squirrel with white belly. White ring around eye.	Calls include rattles, trills, growls, screeches, and barks

1 Visual Identification Tips from Patuxent Bird Identification InfoCenter <http://www.mbr.nbs.gov/id/framlst/infocenter.html>

2 Vocalization descriptions from National Geographic Society's Field Guide to the Birds of North America (1987)

# Sample Datasheet

**1** 0:00 - 4:59

Actual Start Time: 4:31

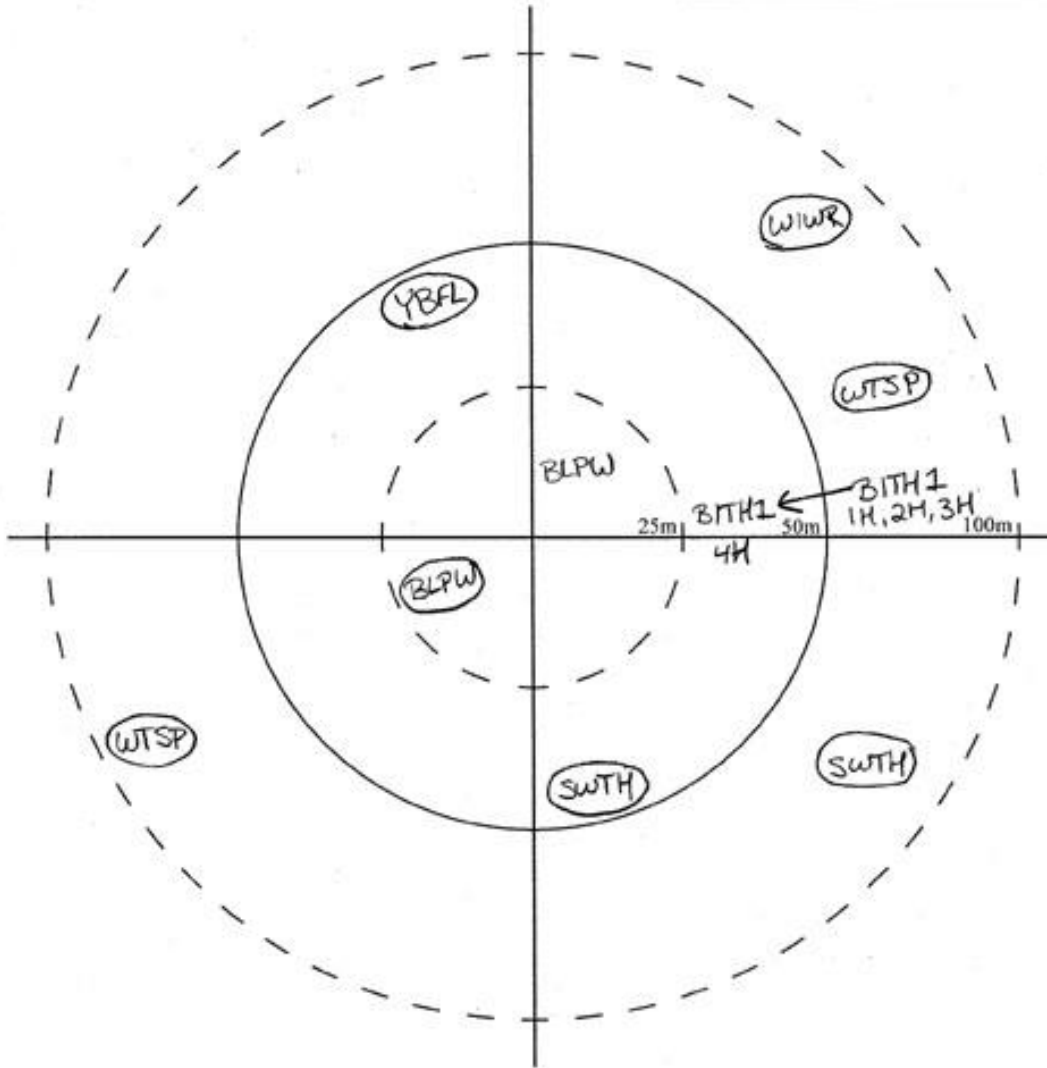

	< 50 m		> 50 m	
	#H	#V	#H	#V
YBFL	1			
BCCH				
BOCH				
WIWR			1	
BITH			1	
SWTH	1		1	
HETH				
BLPW	1	1		
WTSP			2	
FOSP				
RESQ				

*only record each individual once at the distance it was first detected*

Indicate the observation type and distance category of each BITH observation. Observation codes: h = heard; v = visual. Distance codes: 1 = 0-25 m; 2 = 25-50 m; 3 = 50-100 m; 4 = >100 m.

	0obs	0dis	1obs	1dis	2obs	2dis	3obs	3dis	4obs	4dis
BITH1	-	-	H	3	H	3	H	3	H	2
BITH2										
BITH3										
BITH4										

## Field Datasheet

# Mountain Birdwatch

Name \_\_\_\_\_ Date \_\_\_\_\_ Cloud \_\_\_\_\_

Route \_\_\_\_\_ Pt# \_\_\_\_\_ Temp (°F) \_\_\_\_\_ Wind \_\_\_\_\_

CLOUD CODES: 0 = clear or a few clouds; 1 = partly cloudy/variable; 2 = cloudy/overcast; 3 = fog; 4 = drizzle; 5 = showers; 6 = rain  
 WIND CODES: 0 = calm, smoke rises vertically; 1 = (1-3 mph) light air, rising smoke drifts; 2 = (4-7 mph) light breeze, leaves rustle, can feel wind on face; 3 = (8-12 mph) gentle breeze, leaves and twigs move; 4 = (13-18 mph) moderate breeze, moves thin branches, raises loose paper; 5 = (>18 mph) fresh breeze; trees sway; GO HOME!



### PROTOCOL REMINDERS

- \* The most important thing is your safety. Be prepared! Check the weather forecast for the high elevation before you head into the field and pack proper gear. Bring a cell phone and a friend.
- \* Please follow local camping regulations and practice leave no trace guidelines.
- \* Before you begin the count, fill in the top of this datasheet using the weather codes above.
- \* The dashed distance bands on the circle plots are only for estimating the distance to each BITH. For all other species, you only need to mark it as in or out of the 50-m radius.
- \* Record each minute you detect each individual BITH below the code marking its location on the circle plot. Use the minutes on your stopwatch as the minute it is detected, such that a bird heard 30 seconds after the start of the count is recorded as 0H ('0' for 0:30 and 'H' for heard).
- \* Continue tracking each individual BITH for the first 10 minutes using the SAME id number for each individual. For example, if BITH1 is only heard in the first five minutes and BITH2 is heard in both the first five minutes and the second five minutes, still record it as BITH2 in the second period even though you are using a separate circle plot.
- \* Record whether you heard (H) or saw (V) each individual bird. For BITH, write the observation code next to the minute you detected it in (e.g., 1H, 2H, 3V). For each of the other species, use the observation symbols shown below to keep track of whether each was heard or seen and to track the movements of individual birds.
- \* After the count, conduct the cone count protocol and record the data below.
- \* When you return home, transcribe your data into the boxes provided. Make photocopies for your records and mail to your host organization.

**CONE COUNT:** Find the NEAREST balsam fir in each cardinal direction that is at least 4 m tall or 2/3 canopy height and of which you have an unobstructed view of the top 3 m. Count all visible cones. Repeat for the NEAREST red spruce of canopy height. If there are no red spruces visible, note on the datasheet that there were no trees present with an 'X' to distinguish from there being no cones on the tree. Balsam fir cones point up and red spruce cones hang down. Only count the green cones from this year.

#Balsam Fir:	#Red Spruce:
N _____	N _____
S _____	S _____
E _____	E _____
W _____	W _____

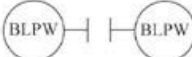
#### OBSERVATION SYMBOLS:

- |  |   |                            |
|--|---|----------------------------|
| BLPW   | - | individual observed        |
|   | - | individual heard           |
|  | - | 2 individuals heard        |
|  | - | known change in position   |
|  | - | assumed change in position |

1 0:00 - 4:59

Actual Start Time: \_\_\_\_\_

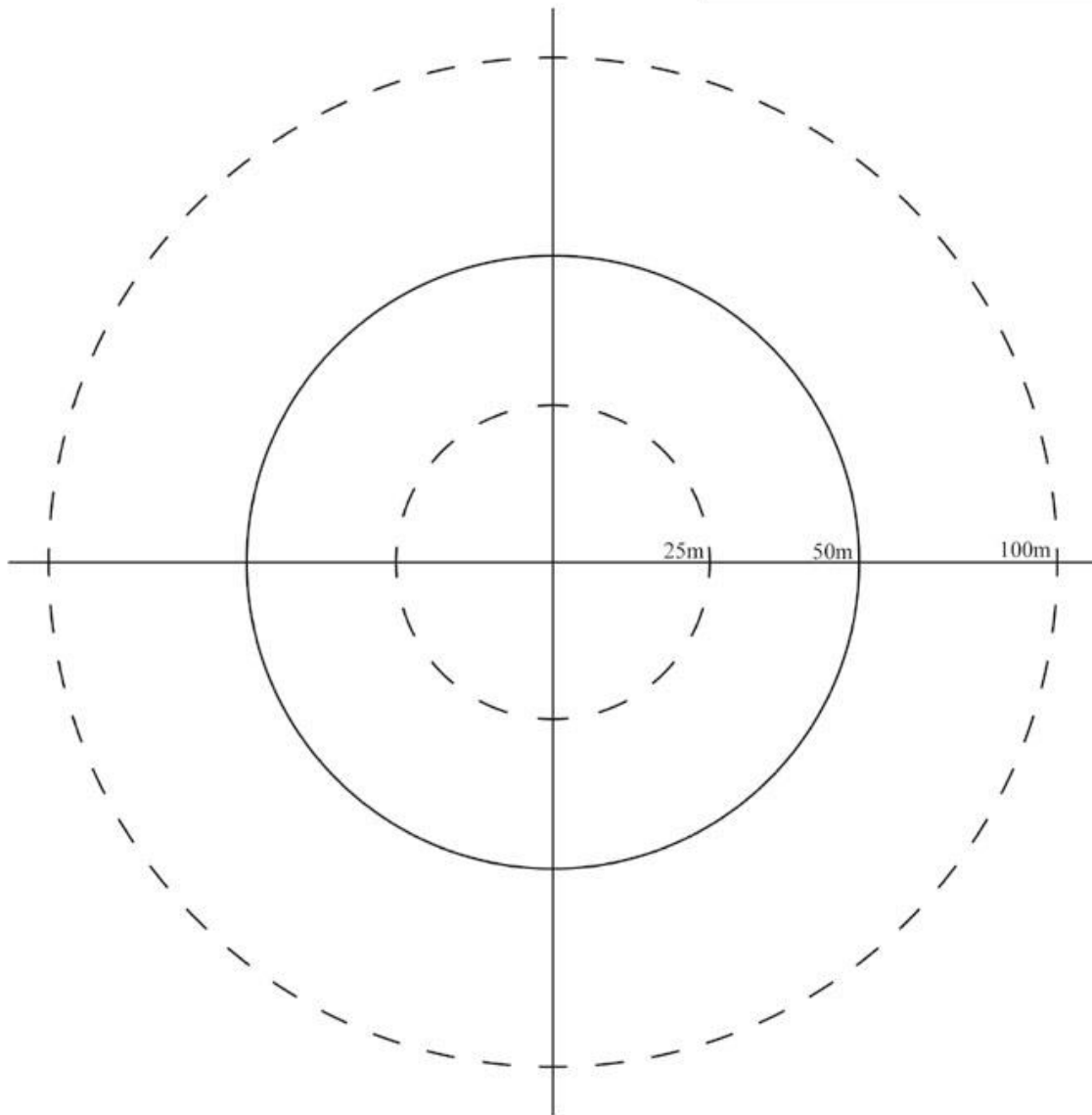

	< 50 m		> 50 m	
	#H	#V	#H	#V
YBFL				
BCCH				
BOCH				
WIWR				
BITH				
SWTH				
HETH				
BLPW				
WTSP				
FOSP				
RESQ				

Indicate the observation type and distance category of each BITH observation. Observation codes: h = heard; v = visual. Distance codes: 1 = 0-25 m; 2 = 25-50 m; 3 = 50-100 m; 4 = >100 m.

	0obs	0dis	1obs	1dis	2obs	2dis	3obs	3dis	4obs	4dis
BITH1										
BITH2										
BITH3										
BITH4										

**2** 5:00 - 9:59

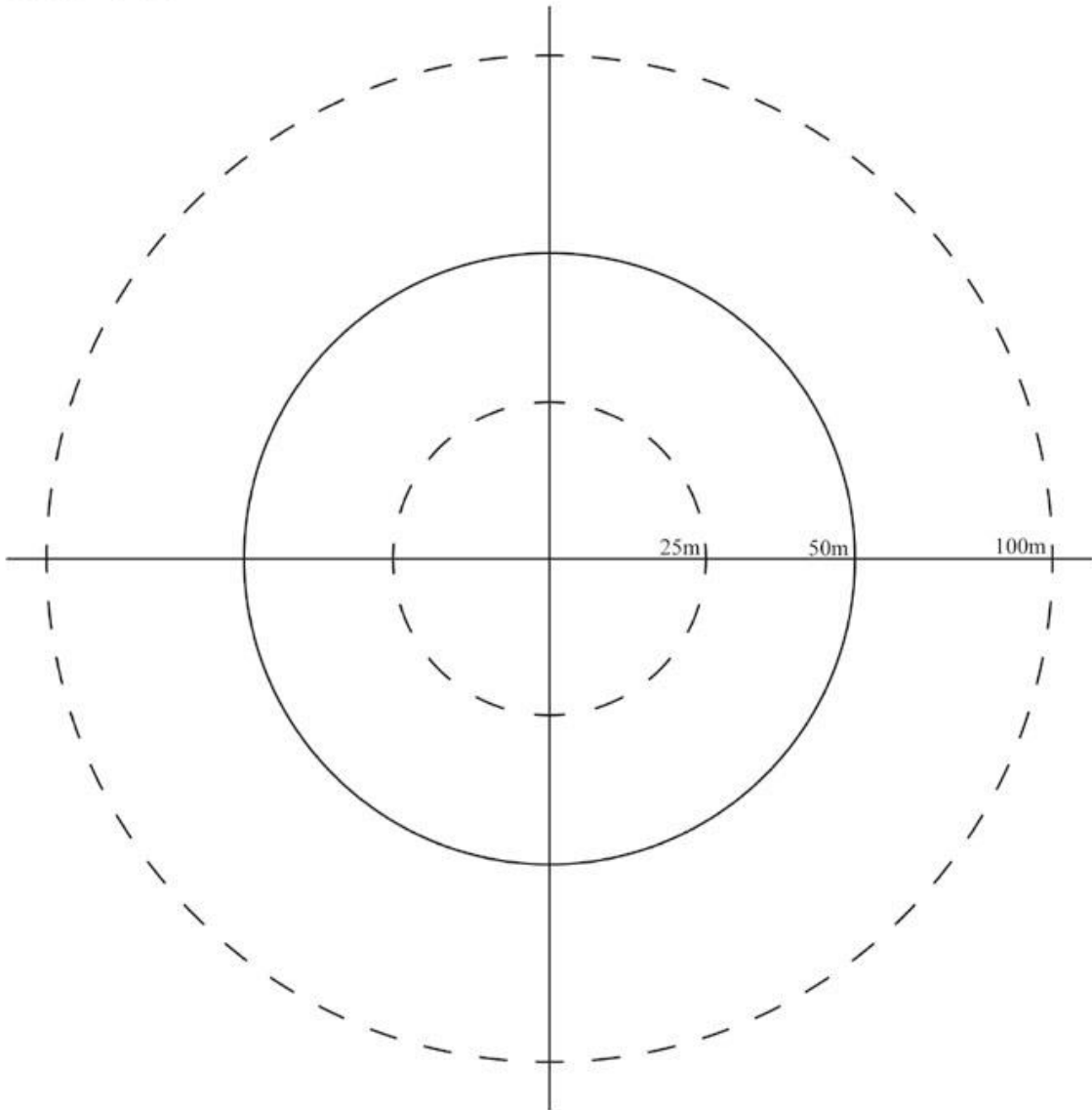

	< 50 m		> 50 m	
	#H	#V	#H	#V
YBFL				
BCCH				
BOCH				
WIWR				
BITH				
SWTH				
HETH				
BLPW				
WTSP				
FOSP				
RESQ				

Indicate the observation type and distance category of each BITH observation. Observation codes: h = heard; v = visual. Distance codes: 1 = 0-25 m; 2 = 25-50 m; 3 = 50-100 m; 4 = >100 m.

	5obs	5dis	6obs	6dis	7obs	7dis	8obs	8dis	9obs	9dis
BITH1										
BITH2										
BITH3										
BITH4										

### 3 10:00 - 14:59

	< 50 m		> 50 m	
	#H	#V	#H	#V
YBFL				
BCCH				
BOCH				
WIWR				
BITH				
SWTH				
HETH				
BLPW				
WTSP				
FOSP				
RESQ				

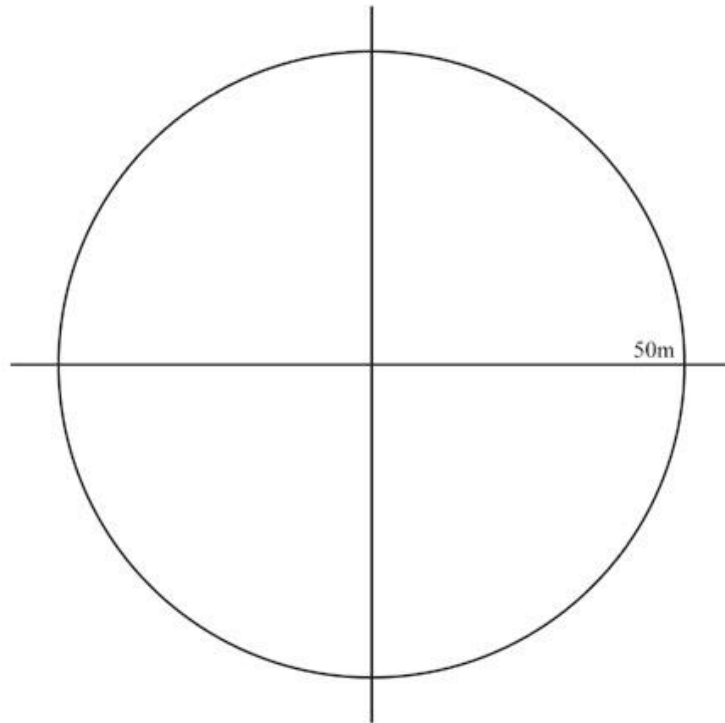

### 4 15:00 - 19:59

	< 50 m		> 50 m	
	#H	#V	#H	#V
YBFL				
BCCH				
BOCH				
WIWR				
BITH				
SWTH				
HETH				
BLPW				
WTSP				
FOSP				
RESQ				

